

DRTTHD**DODGE**

Rear suspension package
Ensemble pour suspension arrière
Ensemble para suspensión de trasero

INSTALLATION INSTRUCTIONS

- Raise vehicle allowing the axle to hang freely.
- Remove existing bump stop assembly.
- Assemble Aeon rubber spring and bracket as shown in the adjacent diagram.
- Using holes in bracket as a template, drill through side of chassis frame rail making sure that Aeon rubber spring is centered over axle.
- Mount Timbren assembly using existing holes & Timbren supplied fasteners.
- Lower vehicle.

NOTES:

Care must be taken to ensure that brake & fuel lines do not interfere with drilling.

INSTRUCTIONS DE MONTAGE

- Soulever le véhicule de sorte que l'essieu soit dégagé.
- Retirer l'assemblage de la butée de suspension existante.
- Assembler le ressort en caoutchouc Aeon et le support comme il est indiqué dans le schéma adjacent.
- Utiliser les trous dans le support à titre de gabarit, percer un trou dans le côté du longeron de cadre de châssis pour s'assurer que le ressort en caoutchouc Aeon est centré sur l'essieu.
- Monter l'assemblage Timbren en utilisant les trous existants et la boulonnerie fournie avec l'assemblage Timbren.
- Redescendre le véhicule.

REMARQUES:

Porter une attention particulière pour s'assurer que la conduite de frein et la canalisation de carburant ne nuisent pas au perçage.

INSTRUCCIONES DE INSTALACIÓN

- Levante el vehículo dejando que los ejes cuelguen libremente.
- Retire la unidad del tope de suspensión existente.
- Ensamble el resorte de caucho Aeon y la abrazadera como se muestra en el diagrama adyacente.
- Utilizando los orificios en la abrazadera como plantilla, perforo a través del larguero del armazón del chasis asegurándose que el resorte de caucho Aeon esté centrado sobre el eje.
- Monte la unidad Timbren utilizando los orificios existentes y los elementos de sujeción Timbren provistos.
- Baje el vehículo.

NOTAS:

Tenga cuidado y asegúrese de que las tuberías de freno y aceite no interfieren con la perforación.

Do not exceed vehicle manufacturer's recommended axle weight rating. Check for AEON[®] interference with vehicle components - Under load AEON[®] will "expand" in diameter.

Ne pas dépasser le poids nominal sur l'essieu recommandé par le fabricant du véhicule. Vérifier que le ressort AEON[®] n'a pas d'incidence sur d'autres pièces du véhicule - Le ressort AEON[®] augmentera son diamètre avec la charge.

No exceda la carga nominal en el eje recomendada por el fabricante del vehículo. Compruebe que no haya interferencia entre el resorte AEON[®] y los otros componentes del vehículo. Bajo carga, el resorte AEON[®] se ampliará en diámetro.

Ref. = Reference = No. de référence = Núm. de referencia
Part = Part #. = No. de pièce = Núm. de pieza
Qty. = Quantity = Quantité = Cantidad

Ref	Part	Qty
1	F31005-150	4
2	F40053-020	4
3	F12106-253	2
4	K10158-003	1L-1R
5	F11102-150	4
6	A01525-65G70	2
7	F31005-250	2
8	F31003-250	4
9	F40031-020	4
10	F12065-653	4

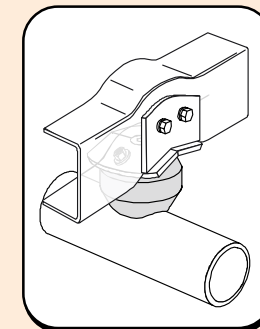
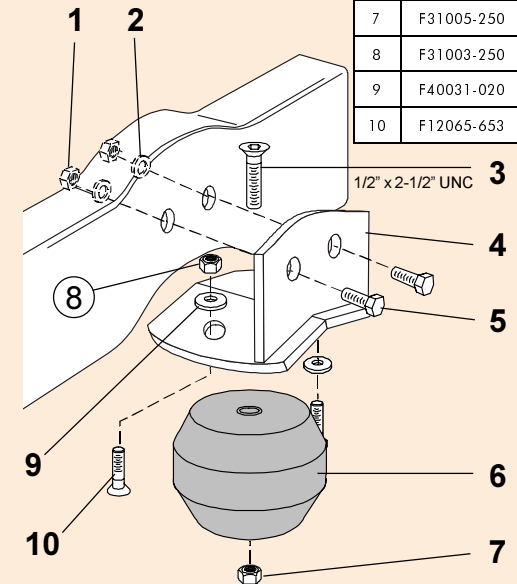

DRTTHD **TIMBREN**

DRTTHD

TIMBREN INDUSTRIES INC.

www.timbren.com

PART NUMBER	DESCRIPTION	QTY	LOCATION
F31003-250	NYLOCK LOCKNUT 3/8 UNC GR 5 Z	4	G1B
F40031-020	WASHER FLAT USS 3/8 x 1 GR 2 Z	4	G1C
F12065-653	FHSCS 3/8 x 2 F/T UNC GR 5 B	4	J2E
F31005-150	NYLOCK LOCKNUT 1/2 UNF GR 5 Z	4	G1D
F40053-020	WASHER FLAT 1/2 x 1-1/2 GR 2 Z	4	G4A
F11102-150	HCS 1/2 x 1-1/2 UNF GR 5 Z	4	G1D
F31005-250	NYLOCK LOCKNUT 1/2 UNC GR 5 Z	2	G1B
F12106-253	FHSCS 1/2 x 2-1/2 UNC GR 5 B	2	J2C

A01525-65G70	Hollow Rubber Spring	2	C18B
--------------	----------------------	---	------

K10158LH-003	DRTTHD WELD'T (PAINTED)	2	E2B
K10158RH-003	DRTTHD WELD'T (PAINTED)	2	E2B

B90223	10-3/4 x 9-1/2 x 7 DW Carton	1	A1A
B10100	NEWSPRINT 18" ROLL	1	
B00029-010	BARCODE LABEL FOR KIT	1	

Issued: 3/23/2007

Clearance Instructions:

Rear SES Kits for Pick-Ups and Vans should have a 1/2" to 1-1/2" gap between the rubber spring and contact point when empty.

A partial load, or vehicle accessories will reduce or eliminate the gap.

Front SES kits are usually in full contact.

Medium and Heavy-Duty Trucks, Trailers and Motorhomes will be in constant contact, and have no gap.

Lifetime Warranty:

Timbren SES Kits are warranted against defects in material and workmanship, under normal use and service, for the life of the vehicle on which the kit was originally installed. The warranty is not transferable and proof of purchase is required. The warranty is limited to the replacement of the failed part.

TIMBREN will not be responsible for any labour or freight charges involved in the replacement of any product. TIMBREN shall be entitled to make its own inspection to determine the validity of the claim. TIMBREN shall not be liable nor warranty the product in the event of alteration, misuse, overload, negligence or damage caused by others.

ASSEMBLY NOTES:

APPLY LEFT/FRONT LABEL TO L/H BRACKET

If ride or performance of our product is unsatisfactory in any way, please call: 1-800-263-3113 or email sales@timbren.com