

13704

ADJUSTABLE RV HITCH

11/26/2018

GROSS LOAD CAPACITY WHEN USED AS A WEIGHT CARRYING HITCH: 5,000 LBS. TRAILER WEIGHT & 500 LBS. TONGUE WEIGHT.



WARNING: * DO NOT EXCEED VEHICLE MANUFACTURER'S RECOMMENDED TOWING CAPACITY *****

FOR MORE INFORMATION LOG ONTO WWW.CURTMFG.COM
HAVING INSTALLATION QUESTIONS? CALL TECHNICAL SUPPORT AT 1-800-798-0813



Parts List			
ITEM	QTY	PART NUMBER	DESCRIPTION
1	4	HFN 1213	HEX FLANGE NUT
2	1	1_2 x 30 FISHWIRE	1/2" x 30" FISHWIRE
3	4	5/8	WASHER
4	4	5/8-11	HEX FLANGE NUT
5	4	CM-SP1	.250 x 1.50 x 2.00" SQUARE HOLE SPACER
6	4	5/8-11 x 1 1/2 HEX BOLT	5/8-11 HEX BOLT
7	4	1/2-13 x 1 1/2	CARRIAGE BOLT

FISHWIRE TECHNIQUE

INSERT COILED END OF FISHWIRE TOOL THROUGH HITCH MOUNTING HOLE IN VEHICLE FRAME RAIL AND OUT THE ACCESS HOLE. PASS COILED END OF FISHWIRE THROUGH SPACER AND THREAD BOLT INTO COIL. KINK WIRE TO KEEP SPACER SEPARATE FROM BOLT AS SHOWN. PULL FISHWIRE, SPACER, AND BOLT THROUGH FRAME AND OUT MOUNTING HOLE. USE FISHWIRE TO GUIDE HITCH DURING MOUNTING AND PREVENT LOSS OF BOLT / SPACER INSIDE FRAME RAIL.

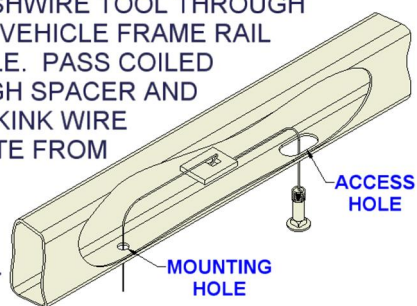

NOTE: SOME VEHICLES MAY FISHWIRE THROUGH END OF FRAME

TOOLS REQUIRED

RATCHET
3/4" SOCKET
11/16" SOCKET
11/16" WRENCH
DRILL
9/16" DRILL BIT
11/16" DRILL BIT
TORQUE WRENCH

HITCH WEIGHT: 60 LBS.

INSTALL TIME

PROFESSIONAL: 30 MINUTES

NOVICE (DIY): 65 MINUTES

INSTALL NOTES:

- DRILLING REQUIRED
- FISHWIRE HARDWARE
- FRAME WIDTH: 22" TO 68.5"

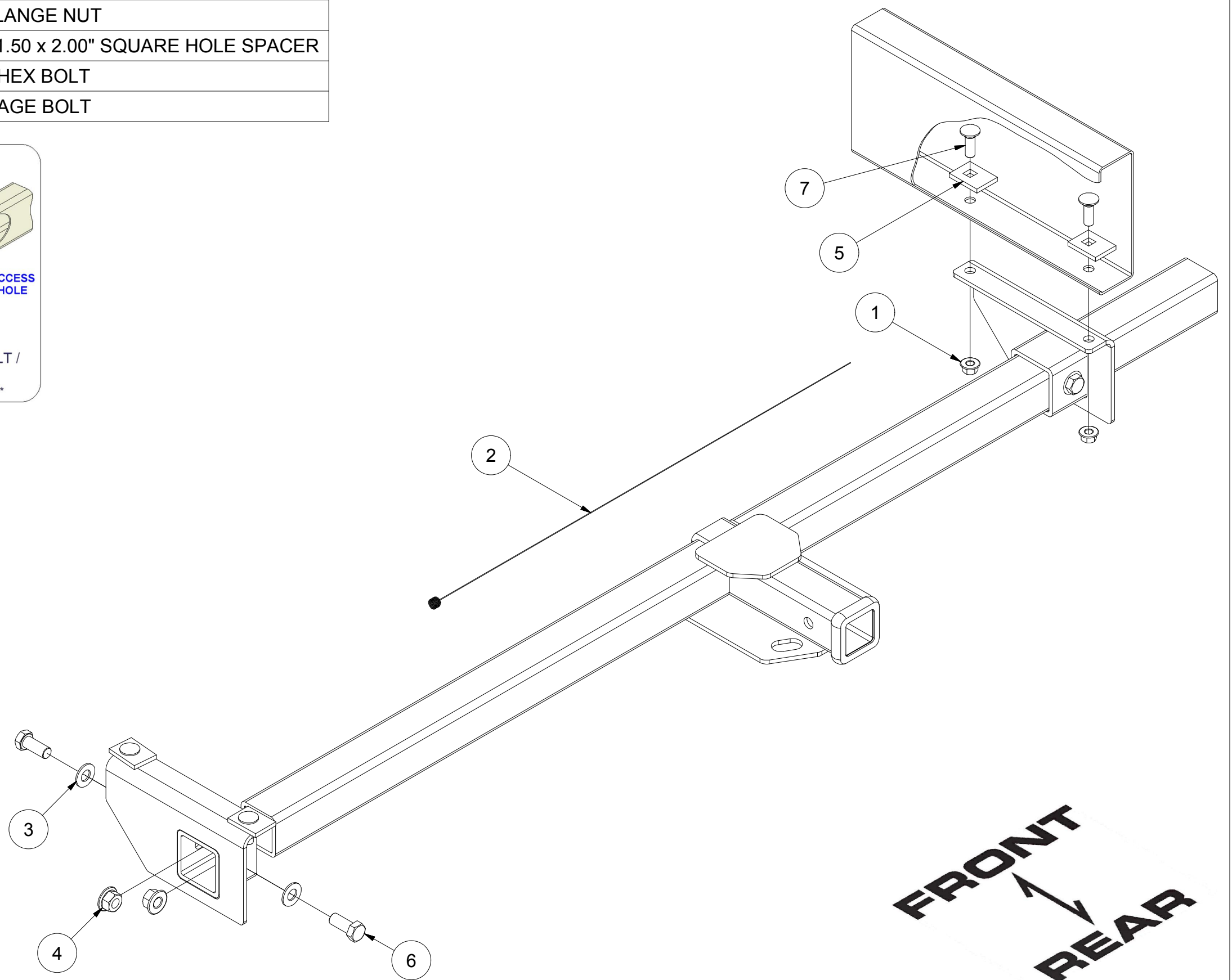

INSTALLATION STEPS

1. Slide the left and right frame brackets onto the main body tube as shown.
2. Position and clamp side brackets to the bottom of frame so the receiver tube with the ballmount is centered on vehicle. Be sure to provide adequate coupler clearance.
3. Using side brackets as a template, drill two holes into frame using a 9/16 drill bit each side.
4. Install 1/2" carriage bolts and spacers through drilled holes in frame and side brackets. If access holes are not present, bolts and spacers may need to be fishwired into frame and/or bumper may need to be loosened for bolt and spacer installation. Loosely install 1/2" flange nuts and remove clamps.
5. Center the main body on vehicle and clamp at both ends to prevent movement while drilling. Drill 11/16 diameter holes through walls of cross tube using the two holes perside (total of four) in the side plate bracket tubes as templates. Install 5/8" hex bolts and flat washer into holes. From inside main body tube, place flange nut onto 5/8 hex bolt and remove clamps.
6. Main body tube may be trimmed flush with outside of side plate bracket. (Note: If trimmed flush, coat bare metal with paint to prevent corrosion.)
7. Torque 1/2" hardware to 110 lb-ft, and 5/8" hardware to 210 lb-ft.



Scan for more information

PERIODICALLY CHECK THIS RECEIVER HITCH TO ENSURE THAT ALL FASTENERS ARE TIGHT AND THAT ALL STRUCTURAL COMPONENTS ARE SOUND.

CURT Manufacturing LLC., warrants this product to be free of defects in material and/or workmanship at the time of retail purchase by the original purchaser. If the product is found to be defective, CURT Manufacturing LLC., may repair or replace the product, at their option, when the product is returned, prepaid, with proof of purchase. Alteration to, misuse of, or improper installation of this product voids the warranty. CURT Manufacturing LLC.'s liability is limited to repair or replacement of products found to be defective, and specifically excludes liability for incidental or consequential loss or damage.

This product complies with safety specifications and requirements for connecting devices and towing systems of the state of New York, V.E.S.C.Regulation V-5 and SAE J684.