

PRODUCT MANUAL

ASSEMBLY, INSTALLATION, AND OPERATION INSTRUCTIONS

For 1.25in & 2in Hitch Receivers
Maximum load weight limit is 40 lbs per bicycle. Rack empty weight is 34 lbs.

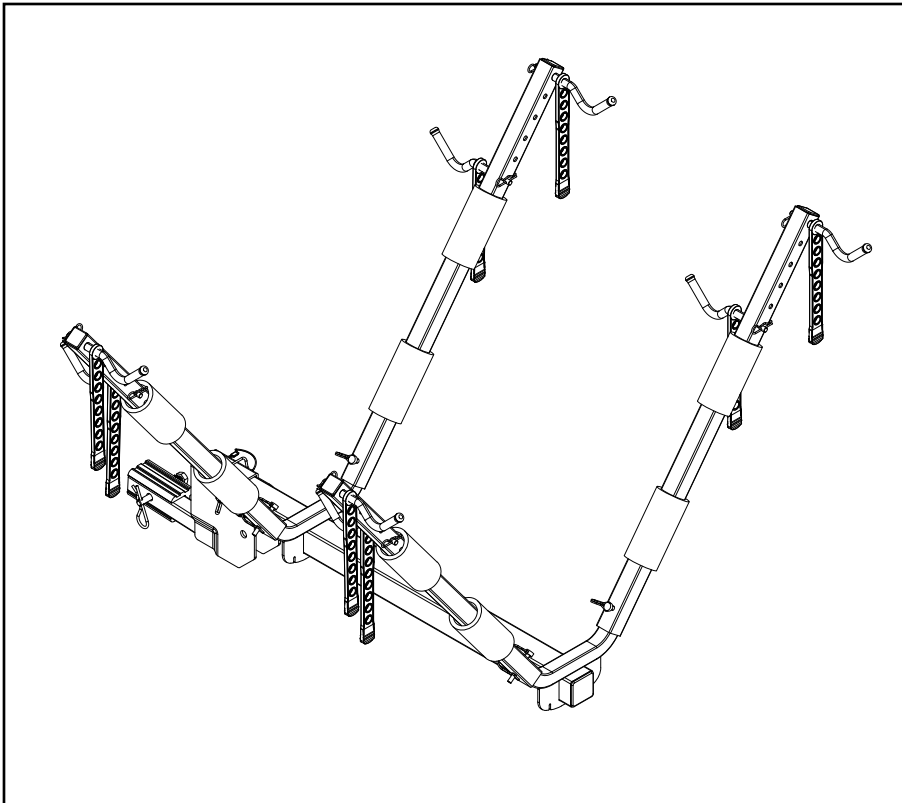

PARTS

QTY. DESCRIPTION

A	1	SHANK
B	1	2IN HITCH ADAPTER
C	2	6MM SOCKET HEAD BOLT
D	1	NOMOTION™ HITCH PIN
E	1	LOCK WASHER
F	1	1/2" FLAT WASHER
G	1	LARGE RETAINER CLIP
H	1	TILT PIN
J	1	12mm BOLT
K	2	12mm FLAT WASHER
L	1	12mm NYLOCK NUT
M	1	MAST
N	8	WHEEL CRADLE
O	8	RUBBER STRAP
P	4	WING
Q	8	SMALL RETAINER CLIP
R	4	WIRE LOCK PIN
S	8	TOGGLE STRAP
	1	HEX TOOL

To register your product, visit the [LetsGoAero.com/registration](https://www.LetsGoAero.com/registration)

For More Information & Accessories, Visit our Website - www.LetsGoAero.com
For Technical Support & Product Questions Contact Us at 877-464-2376 or 719- 630-3800
Email: Support@LetsGoAero.com
Let's Go Aero, Inc. 4474 Barnes Road Colorado Springs, CO 80917, USA

Patent and trademark protected. Patent Number 8,889,456; Patents Pending

NOTICE: All Manual information is subject to change without notice. Revised editions will be available for free download at [LetsGoAero.com](https://www.LetsGoAero.com). Manual information is considered factual until made obsolete by a revised version.

Follow this QR-Code or visit [LetsGoAero.com/manuals](https://www.LetsGoAero.com/manuals) to check for an updated version:



INSTALLATION FOR 2IN HITCHES ONLY

For vehicles with 2in hitches, slide the Shank **[A]** into the hitch receiver and align the pin holes. [Fig. 1]

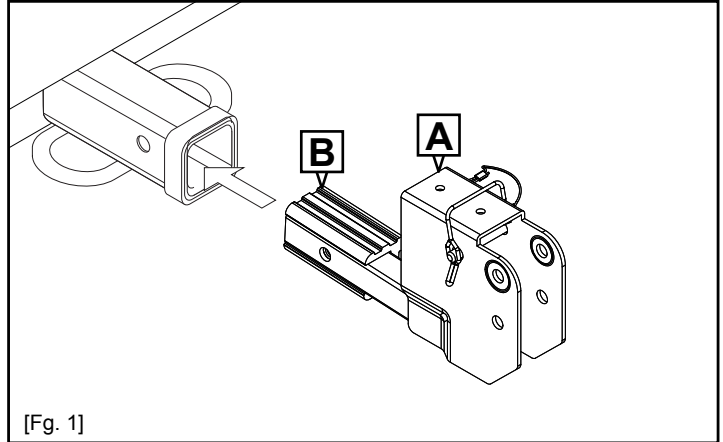

STEP 2: INSTALLATION

For vehicles with 1.25in hitches, unbolt the two 6mm Socket Head Bolts **[C]** connecting the factory installed Hitch Adapter **[B]** to the Shank **[A]** using the Hex Tool provided and remove. [Fig. 2]

Slide the 1.25in Shank **[A]** into the Hitch Receiver and align the pin holes. [Fig. 3]

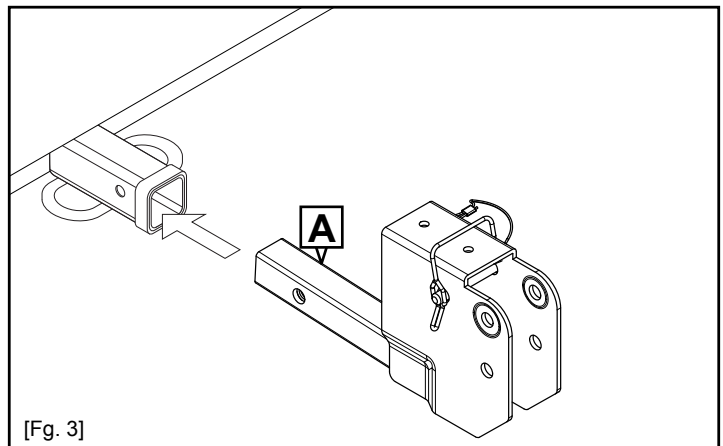
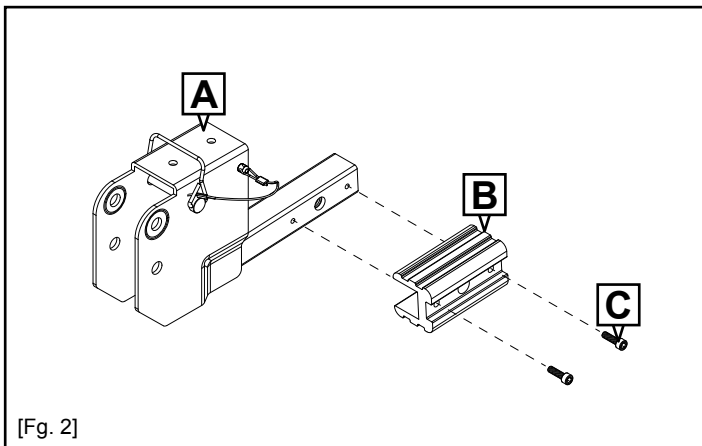

STEP 3: INSTALLATION

RECOMMENDED TOOL: 3/4" WRENCH

Slide the Lock Washer **[E]** and Flat Washer **[F]** onto the NoMotion Pin **[D]** with the Lock Washer positioned closest to the hex head of the NoMotion Pin.

With the pin holes of the Shank **[A]** and hitch receiver aligned, insert the NoMotion Pin **[D]** with the attached Washers **[E & F]** into the vehicle hitch receiver.

Secure the NoMotion Pin **[D]** with the Large Retainer Clip **[G]**. [Fig. 4]

NOTE: For vehicles with 2in Hitch Receivers, the NoMotion Pin must be inserted from the side of the Shank **[A]** where the Hitch Adapter **[B]** is the thickest.

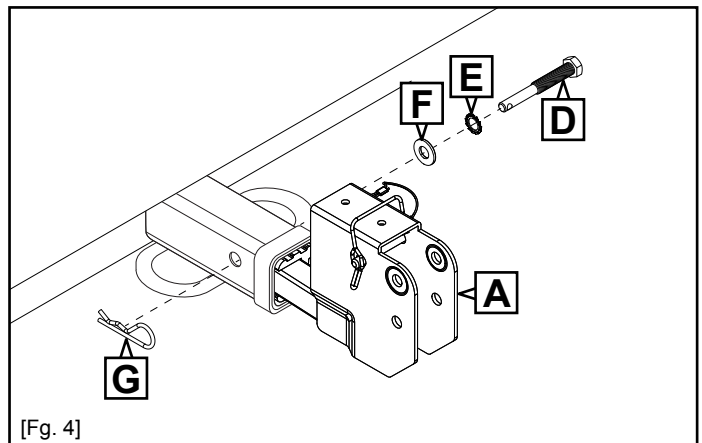

STEP 4: ASSEMBLY

RECOMMENDED TOOL: 3/4" WRENCH

Unlatch the Tilt Pin [H] attached to the Shank [A].

Align the **upper horizontal holes** on the shank with the holes on the end of the Mast [M].

Secure and re-latch the Tilt Pin [H] into the hole located **closest to the vehicle**.

In the 2nd hole, align the Mast [M] to the Shank [A] and secure the Mast using one (1) 12mm Bolt [J], two (2) 12mm Flat Washers [K], and one (1) 12mm Nylock Nut [L] as shown. [Fig. 5]

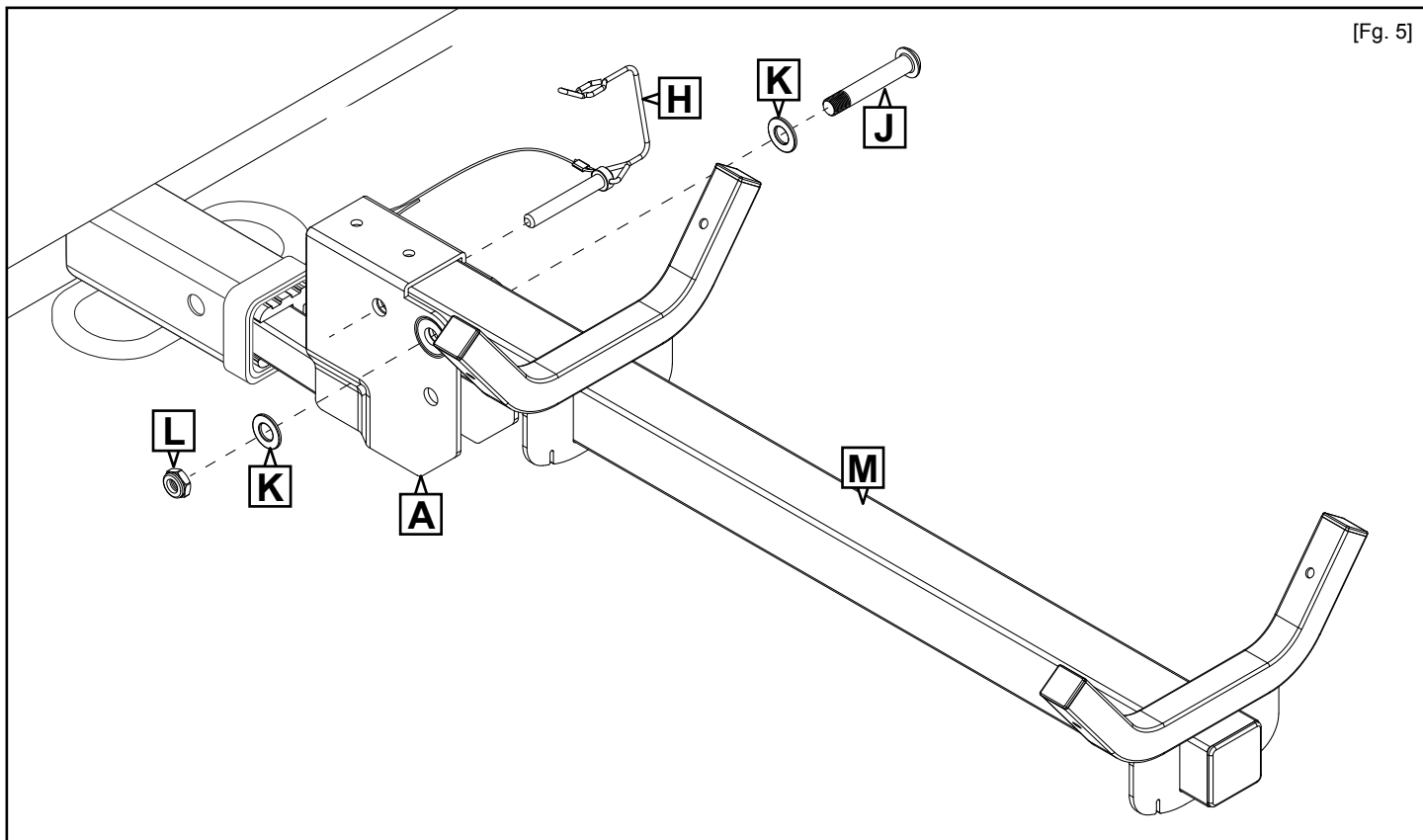

STEP 5: ASSEMBLY

Slide the Foam Bumpers located on each Wing [P] to the center of the Wing to reveal the holes at each end.

Install one Wing [P] onto each side of the Mast [M] uprights. Secure with Wire Lock Pin [R]. [Fig. 6 & 7]

NOTE: The Wire Lock Pin [R] **MUST** always be inserted through the hole in the Mast [M] from above/inside the Mast upright as shown.

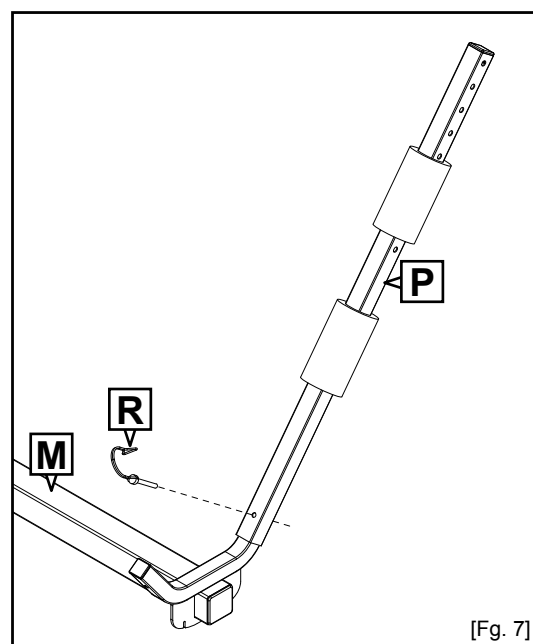
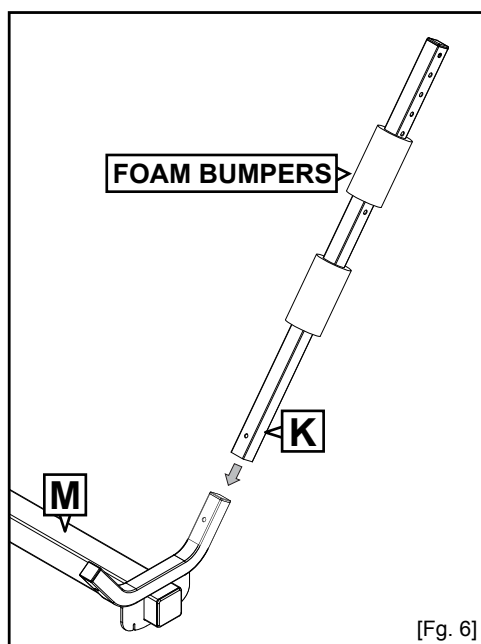

STEP 6: ASSEMBLY

Slide the round end of one (1) Rubber Strap [O] onto each Wheel Cradle [N]. [Fig. 8]

NOTE: Be sure to slide the Rubber Straps [O] all the way onto the cradles so that it tightly rests over the plastic coating of the Wheel Cradle [N].

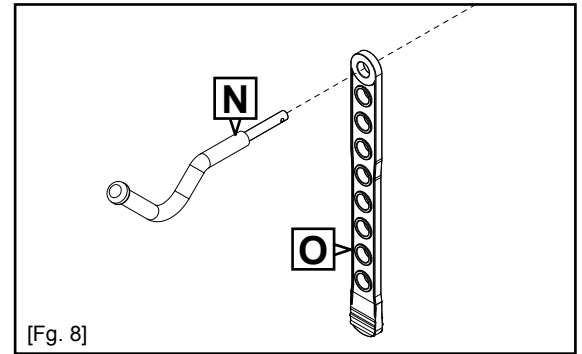

STEP 7: ASSEMBLY

Insert two (2) Wheel Cradles [N] with Rubber Straps [O] facing in opposite directions into the Wing [P] as shown. [Fig. 9]

Secure each Wheel Cradle [N] with a Retainer Clip [Q].

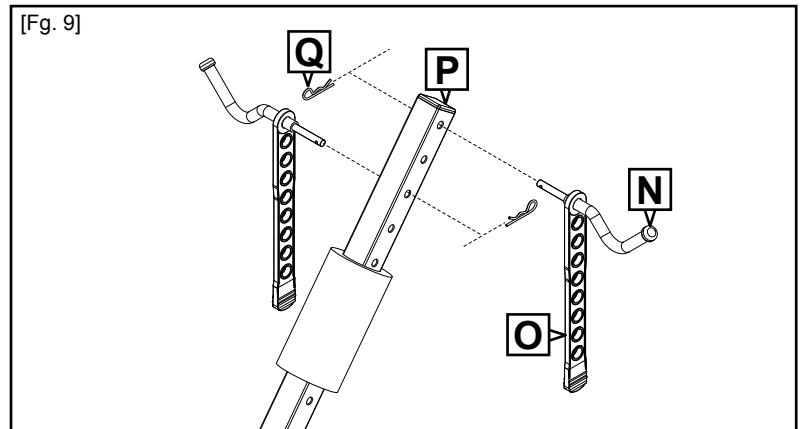

OPERATION: Shank Tilt

Unlatch each Wire Lock Pin and remove all four Wings [P].

Remove the Tilt Pin [H] from the upper hole on the Shank [A].

Tilt the Mast [M] up until it rests vertically and the holes on the Mast re-align with the holes on the Shank [A]. [Fig. 10]

Re-insert the Tilt Pin [H] into the hole located below the 12mm Bolt [J] and secure. [Fig. 11]

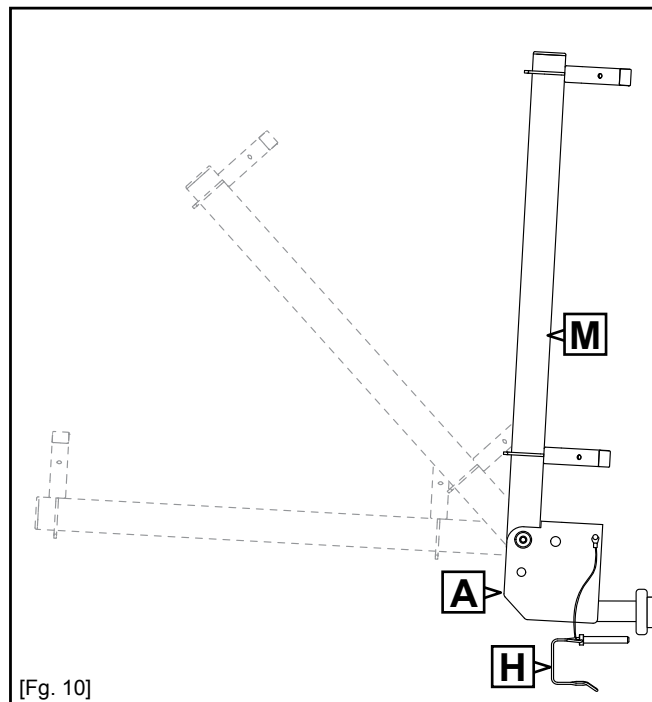

[Fig. 10]

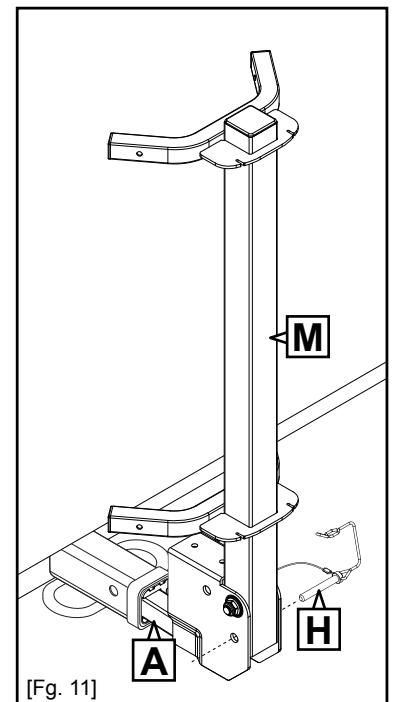

[Fig. 11]

OPERATION: Bicycle Mounting

Hang bicycles by the tires on the Wheel Cradles **[N]** with the chain rings to the outside. [Fig. 12 & 13]

Adjust the Foam Bumpers located on the Wings **[P]** to protect the frame of the bicycle.

IMPORTANT: For two bicycles mounted to same wing, position the bicycles facing in opposite directions (front-to-back/back-to-front) with the chain ring to the outside.

Some adjustment of the Wheel Cradles may be necessary in order to accommodate both bicycles.

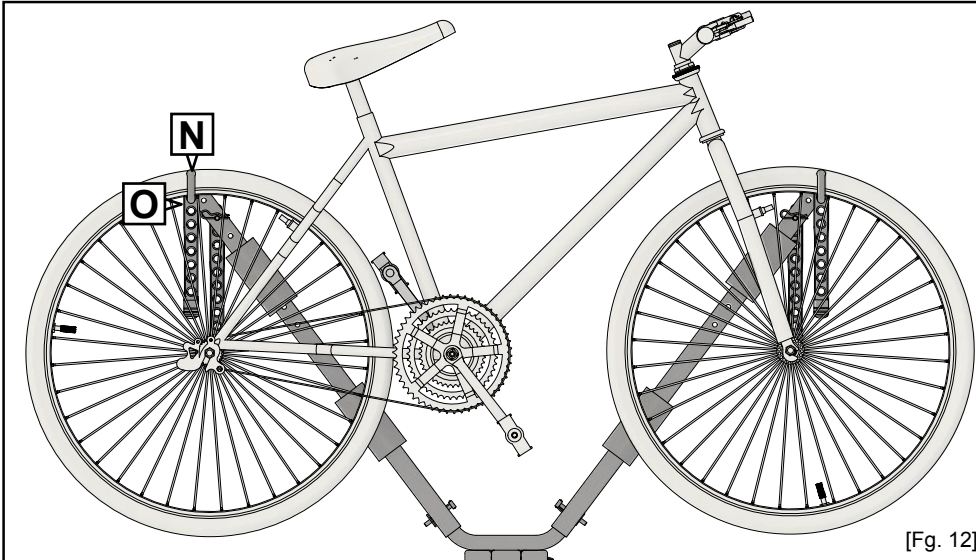

[Fig. 12]

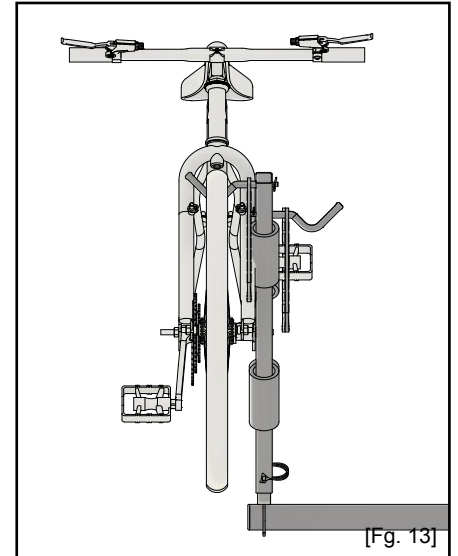

[Fig. 13]

Secure by tensioning each Rubber Strap **[O]** over the top of each tire and engaging a strap hole over the end of the Wheel Cradle **[N]** using the tightest hole available. [Fig. 14 & 15]

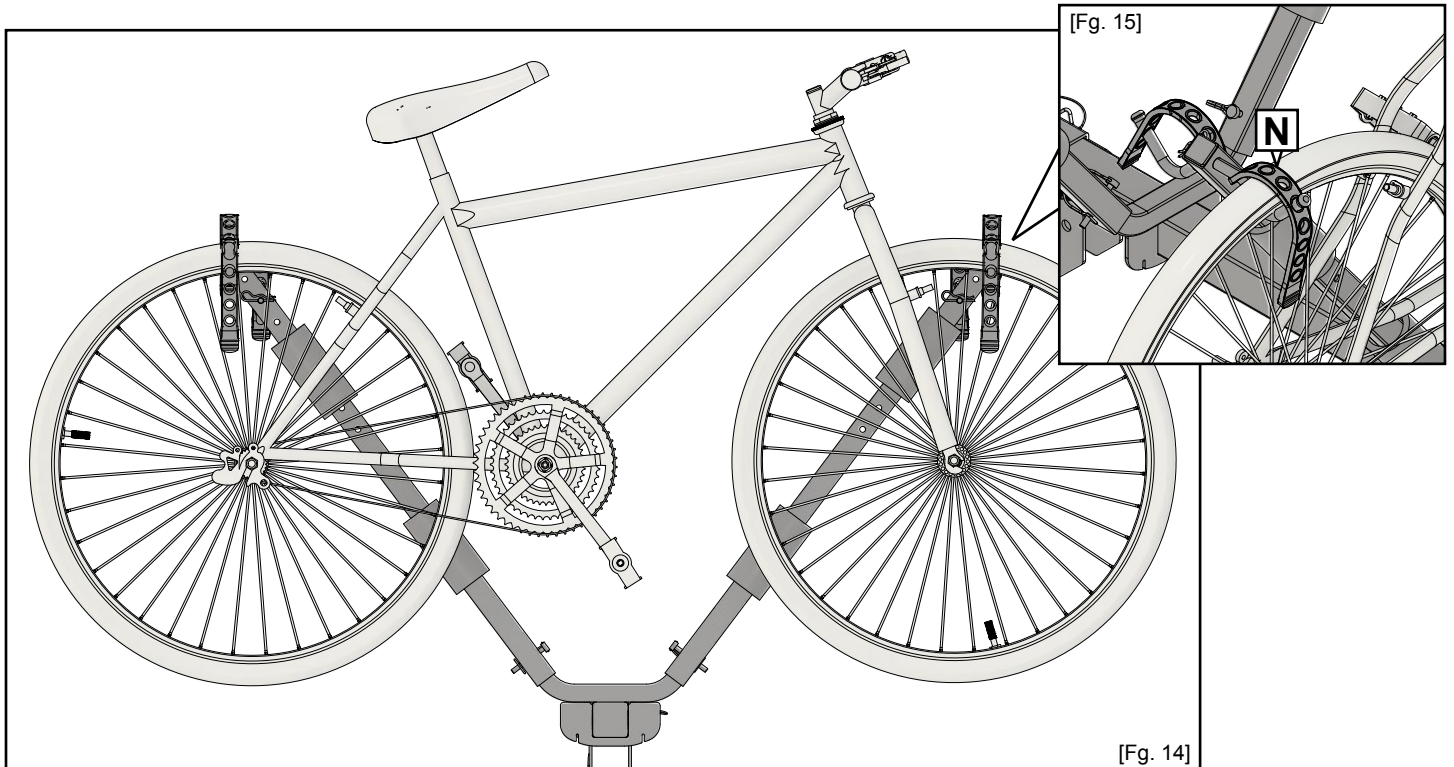

[Fig. 14]

FOR PASSENGER VEHICLE/ MOTORIZED RV USE ONLY:

Continue securing the bike by wrapping the looped end of one (1) Toggle Strap [S] around the outside bike peddle. Pull the bike down and inward against the Foam Pads and then tightly secure the bungee cord to one of the available notches on the base of the Shank [A] using the tightest available toggle ball. [Fig. 15]

NOTE: Wrap excess bungee around the base of the Shank [A] before securing the toggle ball to be sure the Toggle Strap [S] is fully tensioned.

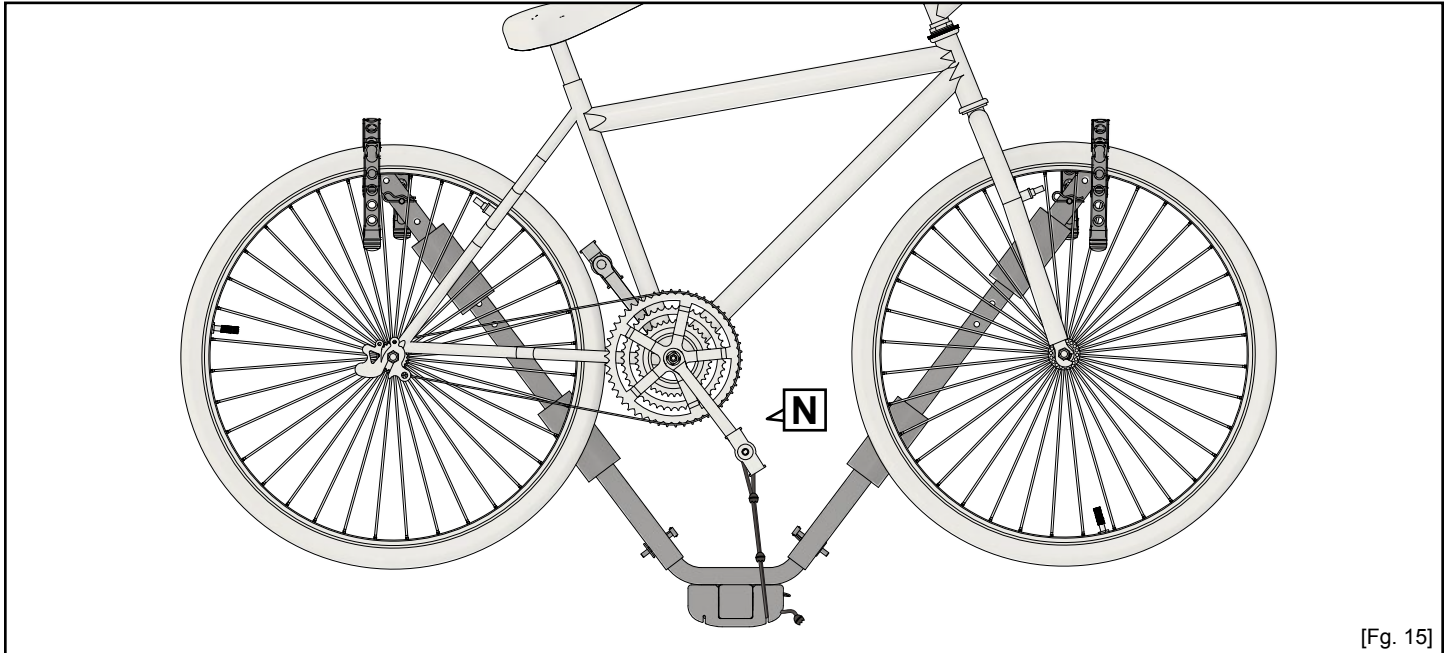

[Fig. 15]

FOR OFF ROAD USE:

Wrap one Toggle Strap [S] around the Wing [P] and front fork tubing of the bike, using one Foam Bumper between the fork and the Wing. Loop the Toggle Strap on itself and secure the Toggle Strap in place by looping one or more of the toggle balls under the tensioned cord.

Wrap one Toggle Strap [S] around the seat stay tubing on the rear of the bike as shown. Position one Foam Bumper between the seat stay and the Wing [P] then loop the Toggle Strap around the seat stay, the Wing and the Foam Bumper. Tension the Toggle Strap securely, and loop the toggle ball under the cord to fix the connection.

▲ WARNING:

ALWAYS SECURE BICYCLES
USING TWO TOGGLE STRAPS
[S] PER BICYCLE AS SHOWN
FOR OFF ROAD USE.

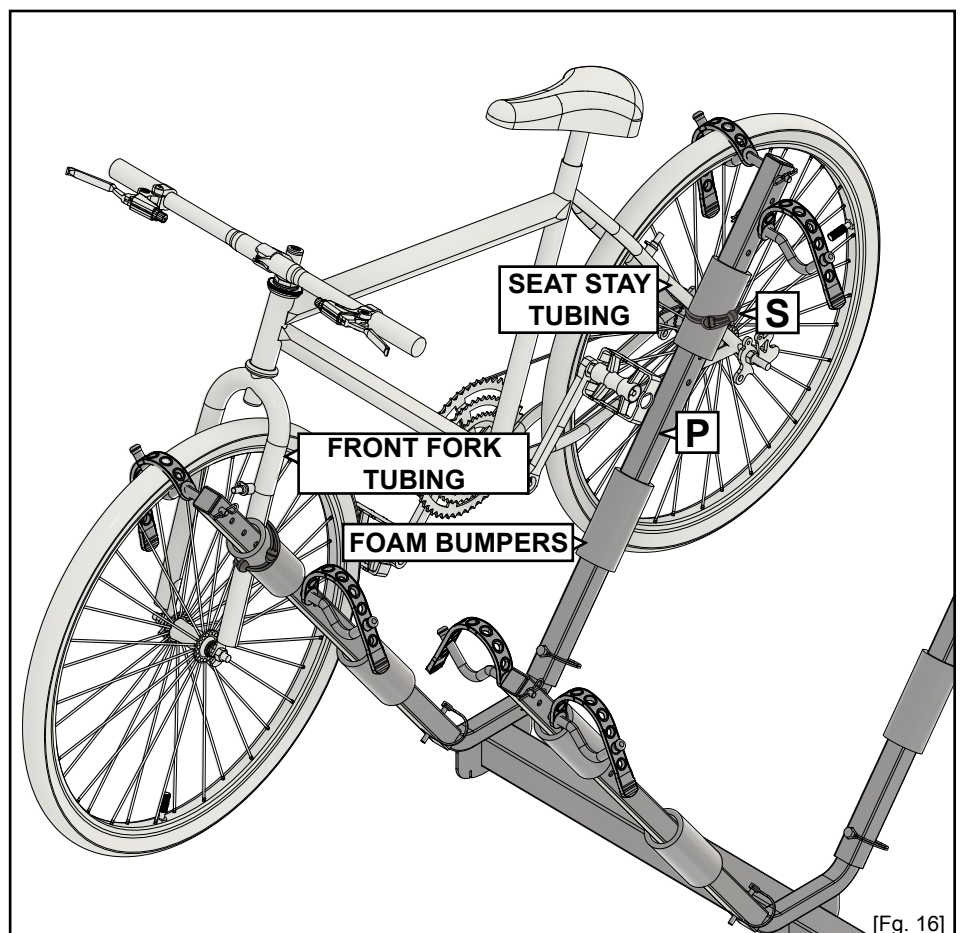

[Fig. 16]

OPERATION GUIDELINES

Keep bicycles away from hot exhaust.

Drive conservatively, especially over bumps.

Bicycles should never extend beyond sides of vehicle.

Approved for passenger vehicles including motorized RV only, not warranted for trailer use including RV travel trailer and 5th Wheels

For use on receiver styler hitch only; not warranted for bolt-on bumper style mount or any other variation.

For best weight distribution, always load heaviest bicycles closest to vehicle hitch and lightest bicycles farther away.

Do not use Let's Go Aero carriers and accessories for purposes other than which they were designed.

MAXIMUM WEIGHT CAPACITY LIMIT

The maximum load weight per bicycle is 40 lbs. Do not exceed this weight per bicycle. Failure to follow this guideline will void the warranty.

⚠ WARNING:

The maximum overall weight limit is 40 lbs per bicycle plus the empty weight of the rack. This limit is always subordinate to the maximum load recommended by the manufacturer of the vehicle itself. It is always the lower maximum recommended load that applies. Do not exceed the load weight limit of the rack or the manufacturer's vehicle receiver hitch tongue weight rating. Consult your vehicle manual for your receiver hitch tongue weight rating. Failure to follow these guidelines or the product's instructions will void the warranty.

⚠ WARNING:

Make sure the NoMotion hitch pin is properly secured by tightening firmly with a wrench. Always check that all bolts and connections are tight and fully secure. Make sure the bicycles are securely attached to the bicycle rack using all required straps provided. Make sure additional care is taken for securing bicycles to rack for motorized RV and off-road use as instructed. Failure to follow proper installation and equipment checks before transit may result in damage to carrier, proper, bodily injury, or death.

⚠ CAUTION:

Car vehicle exhaust can cause a hazard. As a precaution, position bicycles clear of exhaust.

LET'S GO AERO LIMITED 3YEAR WARRANTY

If a Let's Go Aero bike rack is found to have a defect in workmanship or material within a 3-year period of the purchase date of the original purchaser, Let's Go Aero will repair or replace the defect free of charge. This warranty terminates if a purchaser transfers the product to any other person.

The warranty does not cover damage or wear which occurs as a result of day to day use or general wear and tear. No warranty is given for defects caused by normal wear and tear, cosmetic rust, scratches, accidents, unlawful vehicle operation, or modification of, or any types of repair of, a load carrier system other than those authorized by Let's Go Aero.

No warranty is given for defects resulting from conditions beyond Let's Go Aero's control including, but not limited to, misuse, overloading, or failure to assemble, mount or use the product in accordance with Let's Go Aero's written instructions or guidelines included with the product or made available to the purchaser.

Subject to the limitations and exclusions described in this warranty, Let's Go Aero will remedy defects in materials or workmanship by repairing or replacing any parts diagnosed to be at issue without charge for parts or labor. In the event that a product is defective, the purchaser should contact the Let's Go Aero dealer from whom the product was purchased. If the dealer is not able to correct the defect, the purchaser should contact Let's Go Aero in writing to Support@LetsGoAero.com or by phone at 877-464-237 or 719-630-3800.

In the event that a product needs to be returned to Let's Go Aero, a Let's Go Aero technician will provide the purchaser with the appropriate mailing address and any additional instructions. Proof of purchase in the form of an original purchase invoice or receipt, and a detailed description of the defect must be provided. Please note that a Return Merchandise Authorization (RMA) from Let's Go Aero is required for any returns.

DISCLAIMER OF LIABILITY REPAIR OR REPLACEMENT OF A DEFECTIVE PRODUCT OR THE ISSUANCE OF A REFUND OR CREDIT (AS DETERMINED BY LET'S GO AERO) IS A PURCHASER'S EXCLUSIVE REMEDY UNDER THIS WARRANTY. DAMAGE TO A PURCHASER'S VEHICLE, CARGO AND/OR TO ANY OTHER PERSON OR PROPERTY IS EXCLUDED.

THIS WARRANTY IS EXPRESSLY MADE IN LIEU OF ANY AND ALL OTHER WARRANTIES, EXPRESS OR IMPLIED, INCLUDING THE WARRANTIES OF MERCHANTABILITY AND FITNESS FOR A PARTICULAR PURPOSE.

LET'S GO AERO'S SOLE LIABILITY TO ANY PURCHASER IS LIMITED TO THE REMEDY SET FORTH ABOVE. IN NO EVENT WILL LET'S GO AERO BE LIABLE FOR ANY LOST PROFITS, LOST SALES, OR FOR ANY CONSEQUENTIAL, DIRECT, INDIRECT, INCIDENTAL, SPECIAL, EXEMPLARY, OR PUNITIVE DAMAGES OR FOR ANY OTHER DAMAGES OF ANY KIND OR NATURE.

SOME STATES DO NOT ALLOW THE EXCLUSION OR LIMITATION OF INCIDENTAL OR CONSEQUENTIAL DAMAGES, SO THE ABOVE LIMITATIONS MAY NOT BE APPLICABLE. THIS WARRANTY GIVES YOU SPECIFIC LEGAL RIGHTS, AND YOU MAY ALSO HAVE OTHER RIGHTS WHICH VARY FROM STATE TO STATE.

