

INSTALLATION INSTRUCTIONS

EQUIPMENT REQUIRED:
WIRING ACCESS LOCATION: PU3
DRILL BITS:
HITCH REQUIRES 5/8" PIN AND CLIP IF STABILIZING PIN IS NOT INSTALLED.
WRENCHES: (TIGHTEN ALL FASTENERS WITH TORQUE WRENCH) 18mm, 19mm, 3/4, 7/8

VEHICLE	HITCH NO.
CHEVROLET S-10 PICKUP	75085
GMC SONOMA PICKUP (INCLUDING SPORT SIDE BED MODELS)	87464
GMC S-15 PICKUP	
ISUZU HOMBRE	

DO NOT EXCEED LOWER OF
TOWING VEHICLE MFR'S RATINGS OR

HITCH TYPE ▼	MAX GROSS TRLR WT(LB)	MAX TONGUE WT(LB)
WEIGHT DISTRIBUTING	6000	750
WEIGHT CARRYING BALL MOUNT	3500	350

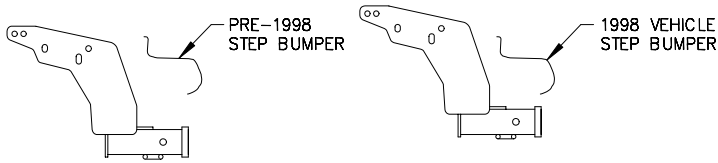

HITCH SHOWN IN PROPER POSITION

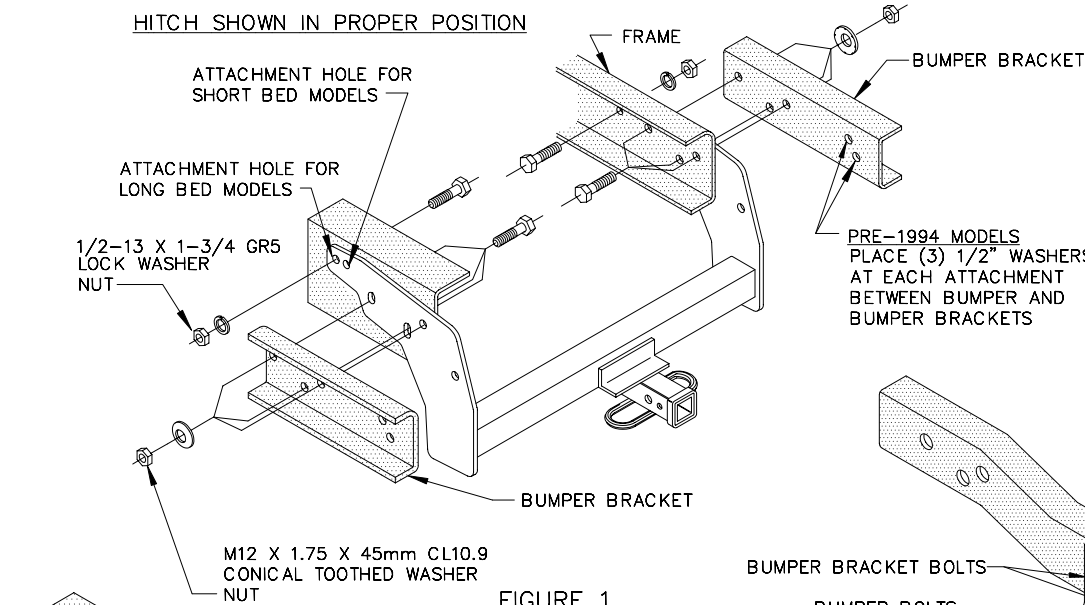

FIGURE 1
PRE-1994

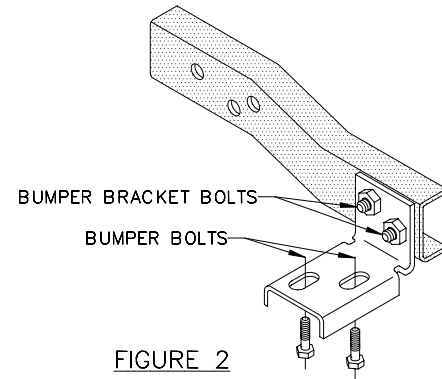

FIGURE 2
1994-1997
BUMPER BRACKET CONFIGURATION
TYP. BOTH SIDES

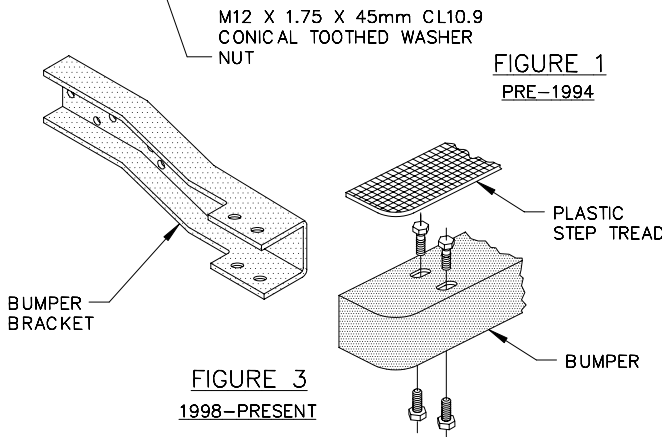
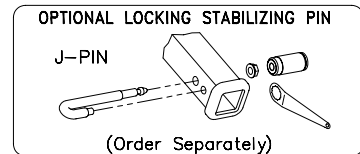

FIGURE 3
1998-PRESENT



SPORTSIDE BED MODELS

NOTE: SOME SPARE TIRES MAY NEED TO BE LOWERED AND REPOSITIONED SLIGHTLY FOR HITCH INSTALLATION.

1. REMOVE BUMPER BRACKET BOLTS AND RETURN TO VEHICLE OWNER.
2. POSITION HITCH ON FRAME AND INSTALL FASTENERS AS SHOWN ABOVE.

STEP BUMPER MODELS

1. REMOVE BUMPER, LEAVING BRACKETS ATTACHED TO FRAME. DISCONNECT BUMPER WIRING BEFORE REMOVING BUMPER.

NOTE: PRE-1994 MODELS, BUMPER IS ATTACHED TO EACH BUMPER BRACKET BY TWO (2) HORIZONTAL BOLTS.

1994-1997 MODELS, BUMPER IS ATTACHED TO EACH BUMPER BRACKET BY TWO (2) VERTICAL BOLTS.

(SEE FIGURE 2.)

1998-PRESENT MODELS, REMOVE PLASTIC STEP TREAD FROM THE TOP OF THE BUMPER. THE BUMPER IS ATTACHED TO EACH BUMPER BRACKET BY FOUR (4) VERTICAL BOLTS.

2. REMOVE BUMPER BRACKETS FROM FRAME. REMOVE BUMPER WIRING GUIDES FROM BUMPER BRACKETS.
NOTE: STEPS 3 AND 4 REQUIRED FOR EARLY MODEL VEHICLES USING A CRADLE STORAGE SYSTEM FOR SPARE TIRE.
3. MARK SPARE TIRE CARRIER 1/8" INBOARD OF OUTBOARD EDGE OF FRAME.
4. LOWER SPARE TIRE AND CUT OFF CARRIER ALONG LINE MARKED.
5. POSITION RECEIVER ON FRAME AND LOOSELY REINSTALL BUMPER BRACKETS USING (3) M12 BOLTS AND FASTENERS PER SIDE. RECEIVER BRACKETS ARE SANDWICHED BETWEEN BUMPER BRACKETS AND FRAME.
6. **PRE-1994 MODELS:** REINSTALL BUMPER ON BUMPER BRACKETS WITH ORIGINAL BOLTS, USING THREE (3) 1/2" WASHERS AT EACH BOLT LOCATION AS SPACERS BETWEEN BRACKETS AND BUMPER. SEE FIG. 1.
1994-PRESENT MODELS: REINSTALL BUMPER ON BUMPER BRACKETS WITH ORIGINAL BOLTS. SLOTS IN BUMPER BRACKET ALLOW FOR ADJUSTMENT.
7. RAISE SPARE TIRE BACK INTO POSITION AND SECURE. RECONNECT BUMPER WIRING.

TIGHTEN ALL FASTENERS TO 75 LB.-FT.

THIS PRODUCT COMPLIES WITH SAFETY SPECIFICATIONS AND REQUIREMENTS FOR CONNECTING DEVICES AND TOWING SYSTEMS OF THE STATE OF NEW YORK AND V.E.S.C. REGULATION V-5.

APPROX WEIGHT (LB.)	37.5	FASTENER KIT NO.	1131-031
---------------------	------	------------------	----------

NOTE: Check hitch frequently, making sure all fasteners and ball are properly tightened. If hitch is removed, plug all holes in trunk pan or other body panels to prevent entry of water and exhaust fumes. A hitch or ball which has been damaged should be removed and replaced. Observe safety precautions when working beneath a vehicle and wear eye protection. Follow car maker's specs for maximum trailer weight and tongue weight. Do not cut access or attachment holes with a torch.

